



AMERICA'S CUP CLASS

PUBLIC INTERPRETATION No 11

October 17, 2005

Page 1 of 2

In response to the following:

Rule 22.1 requires that a winch be positioned on or above the deck. The drum shape of the mainsheet winch is not fully analogous to the drawing in Appendix F. Could you please clarify where the drum is deemed to commence for the purposes of Rule 22.1.

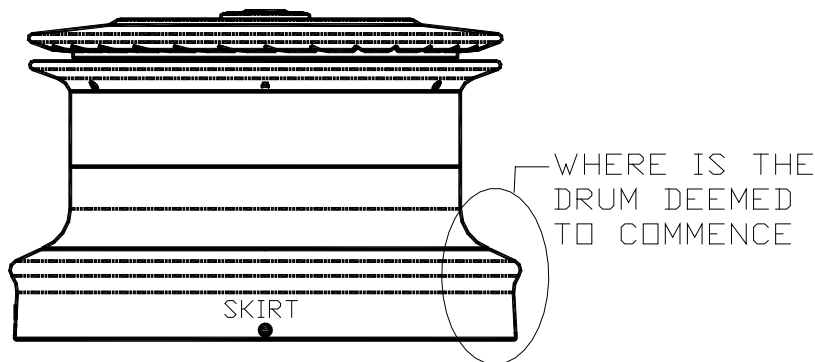

INTERPRETATION

For the purposes of Rules 22.1 the point at which the drum is deemed to commence is dependent on the skirt.

The skirt in the above diagram is taken to be an independently rotating part of the winch which is used as a line control device. An integral base of a winch drum as shown in Figure 1 of Appendix F whose primary purpose is to cover the internal workings of the winch is not a skirt.

If the skirt is driven by the drum, or any other means other than a line wrapped around the skirt, then the drum is deemed to commence at point B.

If the skirt rotates in either one or both directions, and is not driven in any way other than a line wrapped around the drum, the drum is deemed to commence at point A as shown in the sketch below. Point A is the parting line between the drum and the skirt. In this case the skirt is a snubber drum as referred to in rule 22.4.

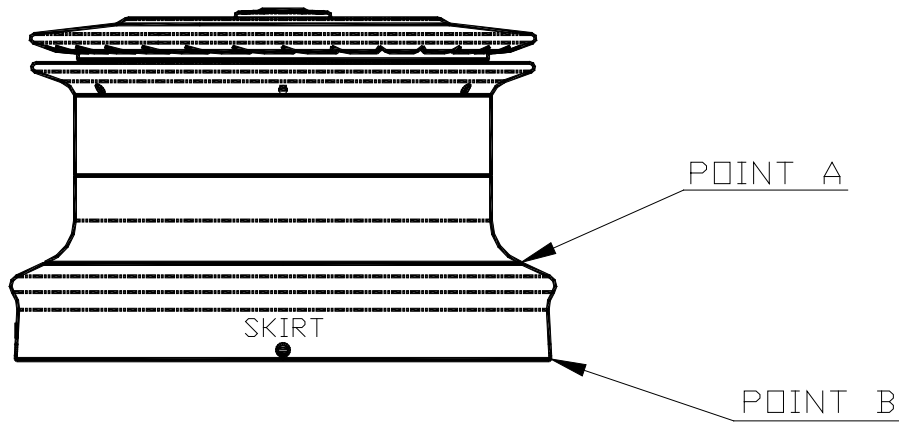

END

This interpretation is made by the CORD Measurement Committee in accordance with Rule 3.3 of Version 5.0 of the America's Cup Class Rule.

*Ken McAlpine
ACC Technical Director
117 Marine Terrace, Fremantle,
W.A. 6160 AUSTRALIA
Phone 61 8 9336 6664
Fax 61 8 9336 6665
Email kenmcalpine@compuserve.com*